



GENERAL DESCRIPTION

The FH4056H is a complete constant-current/ constant-voltage linear charger for single cell lithium battery. There's a temperature loop in the chip. When the chip is overheated, the temperature loop automatically reduces the charging current, ensure safe charging, avoid overheating and obtain maximum charging speed. The charging current can be regulated by external resistance. The Max charging current is 1A. No enable function, No NTC function.

FEATURE

- Input voltage range 4.5V~6.5V, Maximum Voltage for the Power Input 30V
- Charging battery voltage 4.2V/4.35V/4.4V (4.35V, 4.4V Charging voltage can be customized)
- Accuracy of charging voltage $\pm 1\%$
- Trickle/constant current/constant voltage charging
- Maximum constant current charging current 1A; External resistance adjustable
- Constant current charging accuracy $\pm 10\%$
- VIN OVP 6.5V (VIN OVP can be customized to 21v)
- When the chip is overheated, the temperature loop automatically reduces the charging current
- Battery anti-irrigation protection : Static power consumption 30 nA
- Support single color light/dual color light display mode
- Package : SOT23-6, DFN2*2, ESOP8
- ESD 2KV

APPLICATION

- TWS
- IOT Gadgets
- Wearable Devices
- Credential Keys
- Wireless Remote
- Electric toothbrush
- Electric shaver
- Electronic cigarette
- Other applications



ORDERING INFORMATION

Part Number	Package Type	Package Quality	Op Temp(°C)
FS4056H5	SOT23-5	3000	-40~85
FS4056H6	SOT23-6	3000	-40~85
FS4056H8	ESOP8	4000	-40~85
FS4056H	DFN2*2	3000	-40~85

MARK INFORMATION

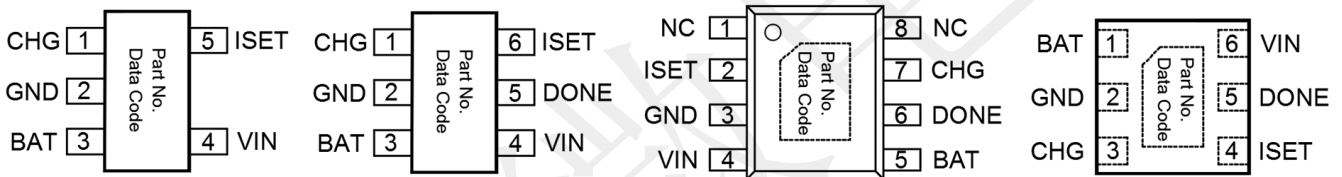

CONFIGURATION

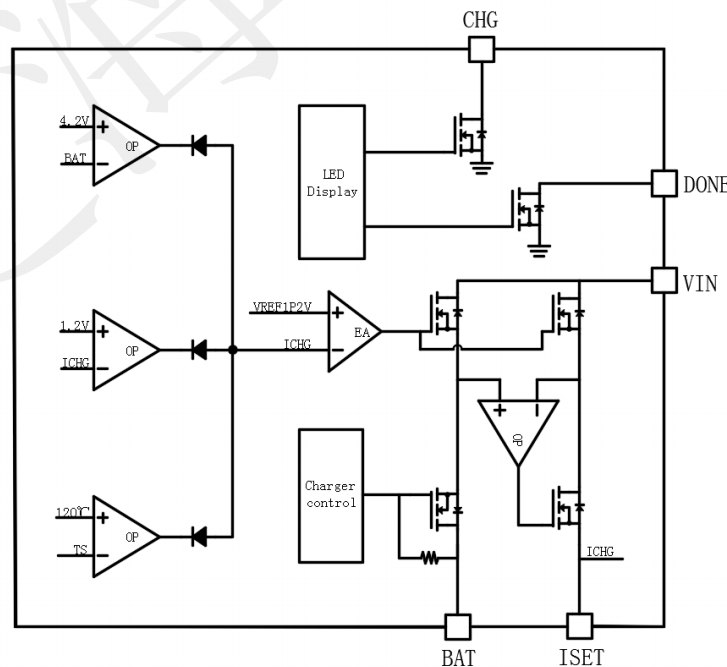



PIN FUNCTIONS

Pin Name	PIN Number				Description
	SOT23-5	SOT23-6	DFN2*2	ESOP8	
CHG	1	1	3	7	Open drain charge status output
GND	2	2	2	3	Ground
BAT	3	3	1	5	Charge current output.
Vin	4	4	6	4	Power supply input, Vin can range from 4.5V to 6.5V
DONE		5	5	6	Open drain charge status output for full
ISET	5	6	4	2	Charge current program/monitor and shutdown pin IBAT=1V*0.88K/ISET
				1	NC
				8	NC

PACKAGE

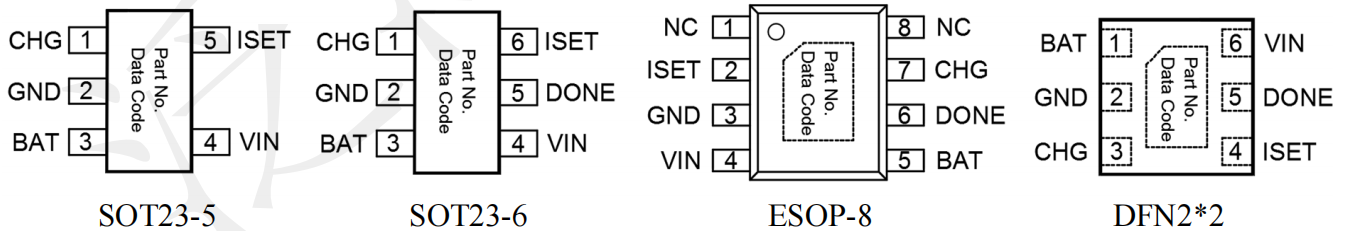



THERMAL METRIC			UNIT	
ESOP8	θ_{JA}	Package thermal impedance ⁽¹⁾	45	°C/W
SOT23-6	θ_{JA}	Package thermal impedance ⁽¹⁾	180	°C/W

THERMAL CHARACTERISTICS

over operating free-air temperature range (unless otherwise noted)

(1) The package thermal impedance is calculated in accordance with JESD 51-7.

ABSOLUTE MAXIMUM RATINGS⁽¹⁾

Over recommended operating free-air temperature range (unless otherwise noted)

Parameter	Symbol	Min	Type	Max	Unit
Input voltage range	V_{IN}	-0.3		36	V
Battery voltage range	BAT	-0.3		11	V
Junction temperature range			125		°C
Storage temperature range		-40		150	°C
HBM(Human Body Model)	ESD		2K		V

RECOMMENDED OPERATING CONDITIONS

parameter	Symbol	Min	Type	Max	Unit
Input voltage range	V_{IN}	4.5	5	21	V

* Beyond these working conditions, the operating characteristics of the device can't be guaranteed °



ELECTRICAL CHARACTERISTICS

Chip working condition is 25°C except special specification

parameter	Symbol	Test conditions	Min	Type	Max	Unit
Input voltage range	V _{IN}		4.5	5	6.5	V
Input under voltage	V _{IN_UVLO}			3.64		V
	slow-moving			0.36		V
Input overvoltage	V _{IN_OVP}	VIN_OVP=21.5V Customizable		6.5		V
	slow-moving			0.5		V
VIN-VBAT	VSD	VIN-VBAT up and charge	160	200	240	mV
		VIN-VBAT down, Turn off charge	60	90	120	mV
Input static current	I _Q	VIN=5V, VBAT=10uF		0.34		mA
Trickle charge current	I _{trick}			0.1*ICC		A
Trickle charging to constant current charging threshold				3.03		V
Constant current charging to trickle charging threshold				2.82		V
Constant current charging current	ICC	RISET=880		1		A
Accuracy of constant current charging current				±5		%
Full voltage	BAT	4.35V/4.4V Customizable		4.2		V
Accuracy of full voltage				±0.5		%
Battery overvoltage				102%*VBAT		V
Charging cut-off current	I _{term}			0.1*ICC		A
Charging cut-off time	T _{term}			2		s
Recharge threshold	V _{BAT_rechg}	Full voltage=4.2V		3.95		V
Temperature loop threshold				120		°C



LED DISPLAY MODE

	Charge	Full voltage	VIN_OVP
Default	CHG 1HZ, twinkle	CHG, Lights on	CHG , Lights out
Customizable	CHG, Lights on/DONE Lights out	CHG , Lights out/ DONE, Lights on	CHG, DONE, Lights out

CHARGER CURRENT SET

Formula for setting charging current : $I=880/RISET$

Such as: $RISET = 1.76k$; Charging current $I=880/1.76k=500mA$

Charging curve

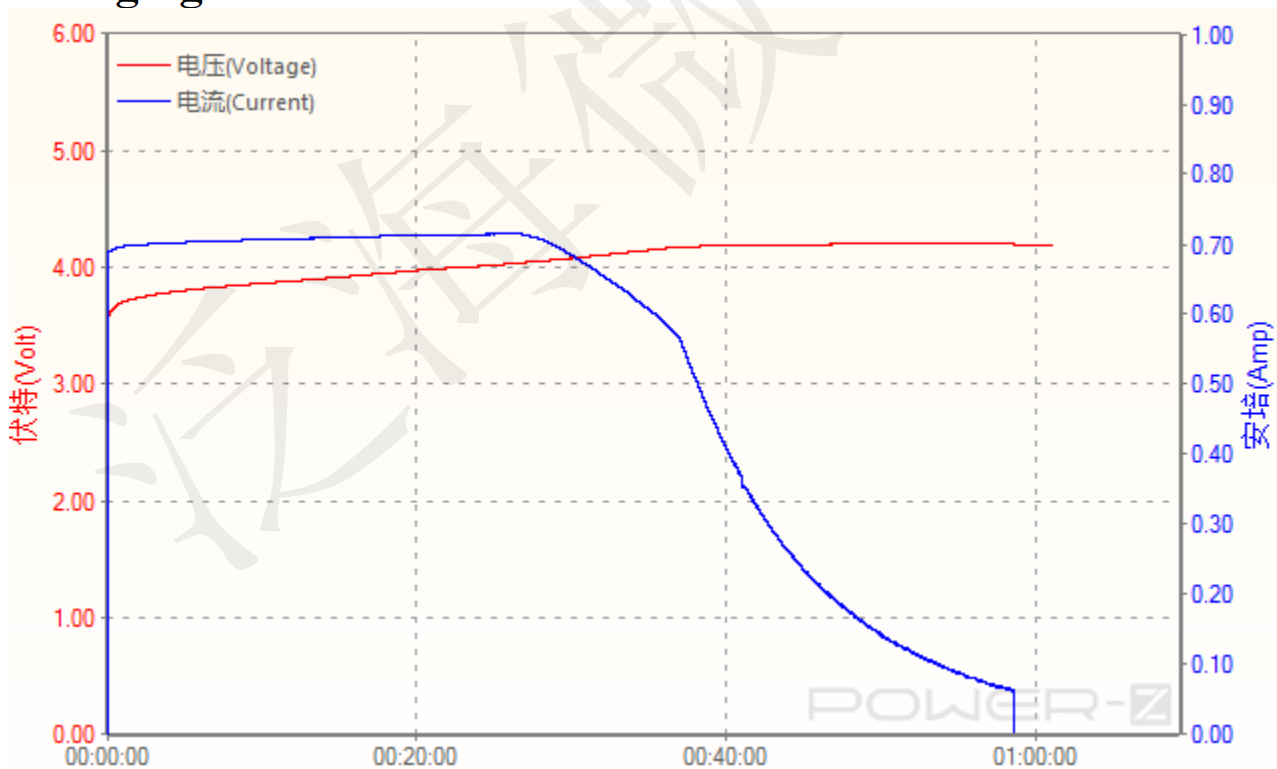



SOT23-6 Typical Application Circuit

SOT23-6 封装原理图

单灯 闪

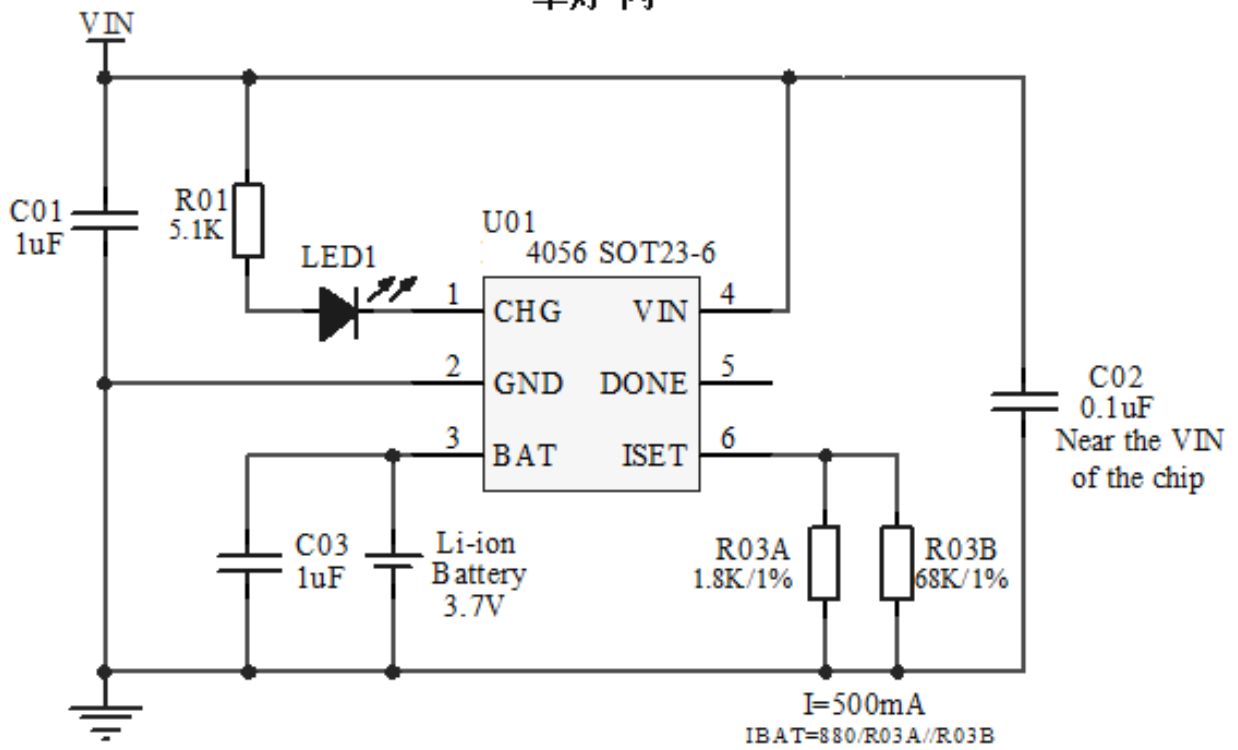



SOT23-6 Typical Application Circuit

SOT23-6 封装原理图
双灯转

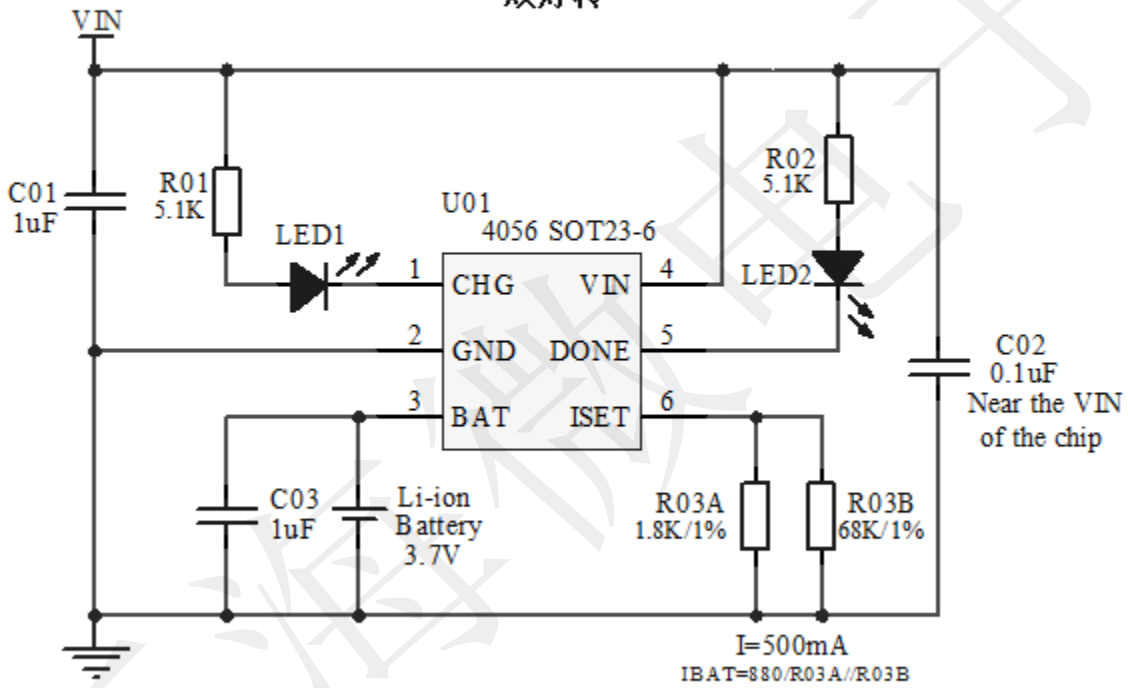



ESOP8 Typical Application Circuit

ESOP8 封装原理图
双灯转

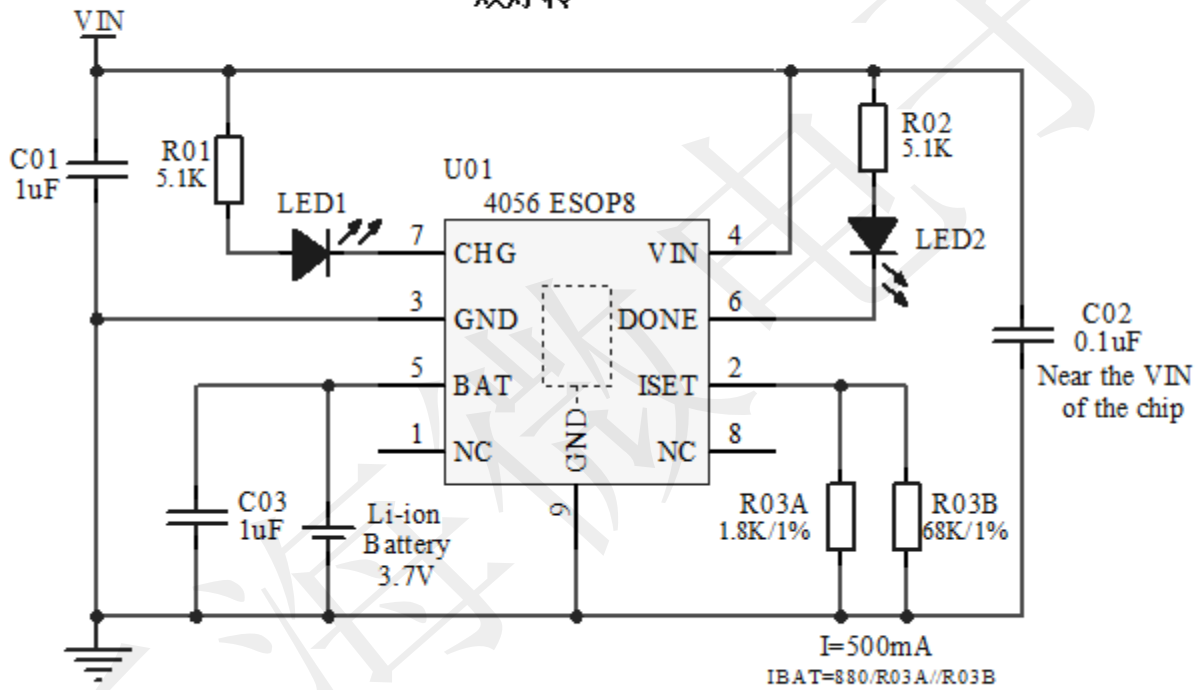



Package information

SOT23-5

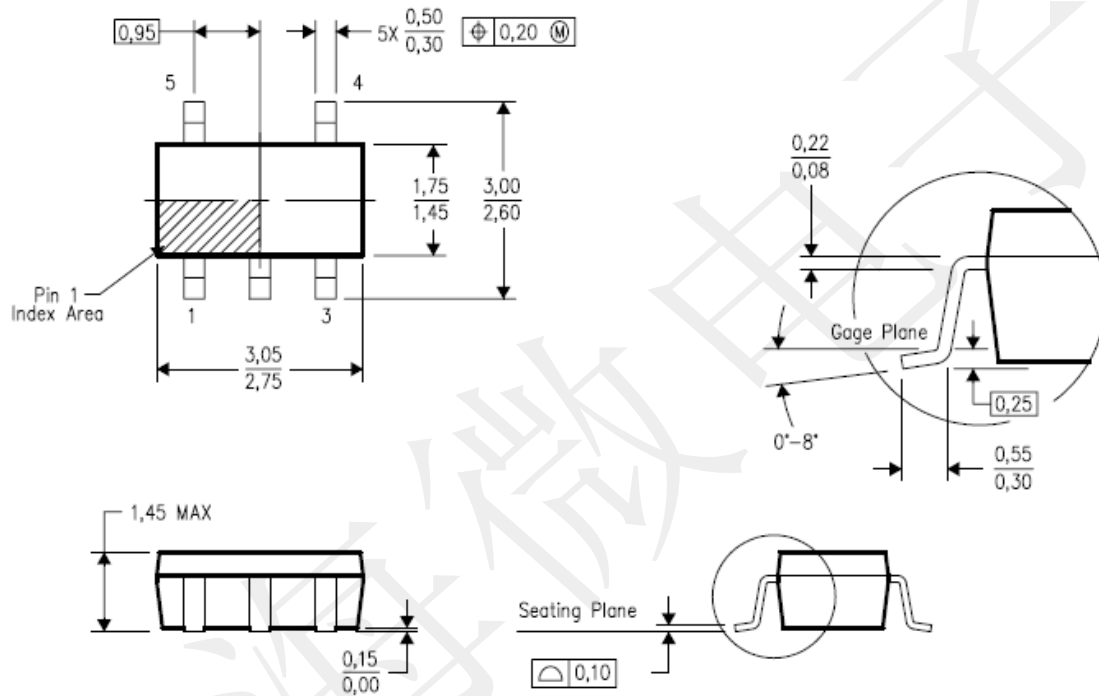



SOT23-6

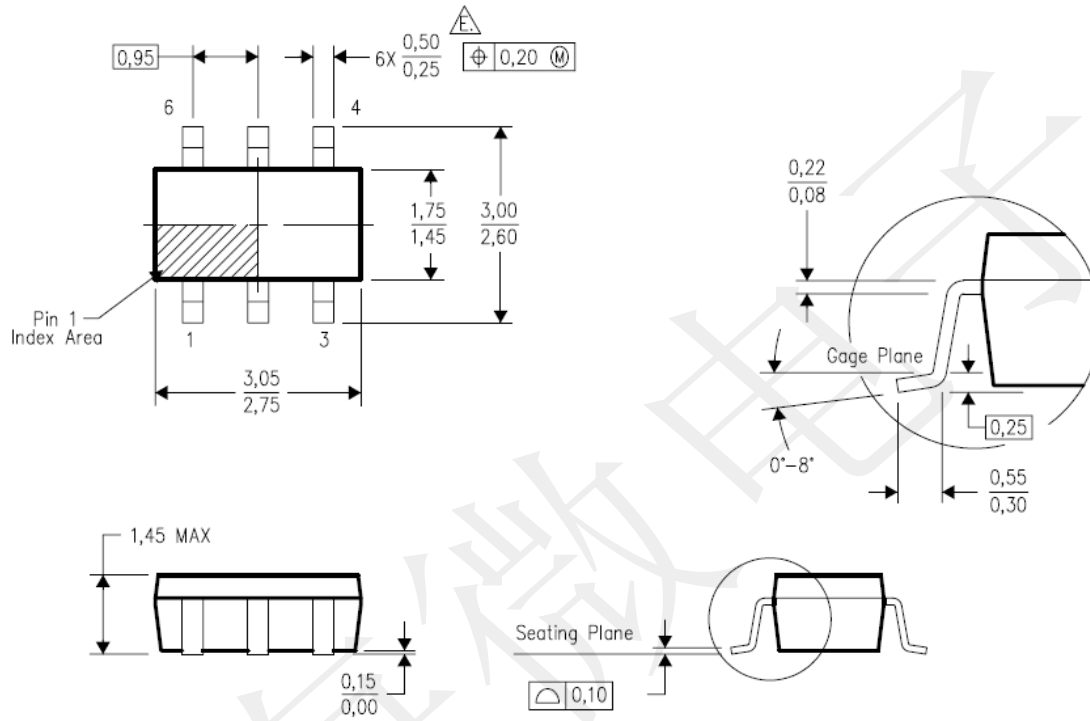



ESOP8

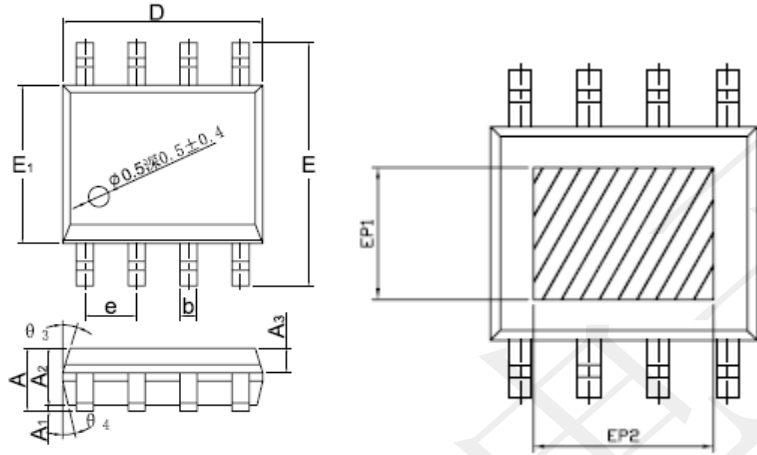

DIMENSIONS IN MILLIMETERS

SYMBOL	MIN	NOM	MAX
A	1,35	1,55	1,75
A ₁	0,00	—	0,10
A ₂	1,25	1,40	1,65
A ₃	0,50	0,60	0,70
b	0,39	—	0,49
b ₁	0,28	—	0,48
c	0,10	—	0,25
c ₁	0,10	—	0,23
D	4,80	4,90	5,00
E	5,80	6,00	6,20
E ₁	3,80	3,90	4,00
e	1,27BSC		
L	0,45	—	1,00
L ₁	1,04REF		
L ₂	0,25BSC		
R	0,07	—	—
R ₁	0,07	—	—
h	0,3	0,4	0,5
θ_1	0°	—	8°
θ_2	11°	17°	19°
θ_3	11°	13°	15°
θ_4	15°	17°	19°
θ_5	11°	13°	15°
EP1	2,40	—	—
EP2	3,30	—	—

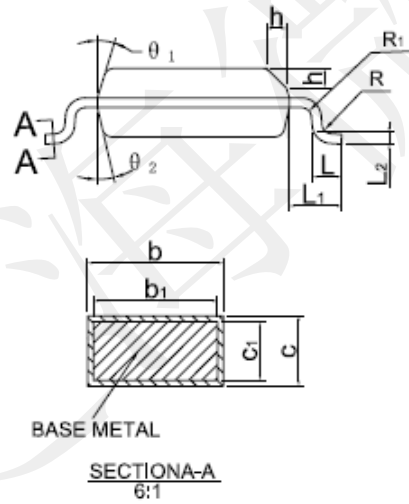



TDFN-2×2-6L

标注 \ 尺寸	最小 (mm)	标准 (mm)	最大 (mm)	标注 \ 尺寸	最小 (mm)	标准 (mm)	最大 (mm)
A	0.70	0.75	0.80	E2	0.75	0.80	0.85
A1	0.00	0.02	0.05	e	0.650BSC		
b	0.30	0.35	0.40	Nd	1.300BSC		
c	0.18	0.20	0.25	K	0.20	-	-
D	1.95	2.00	2.05	L	0.28	0.33	0.38
D2	1.25	1.30	1.35	h	0.15	0.20	0.25
E	1.95	2.00	2.05				

