



80V High Input Voltage LDO Linear Regulators

GENERAL DESCRIPTION

FS8600 series is designed for power sensitive applications. It includes a precision and high voltage input stage, an ultracurrent branch, and results in a ultra and low-dropout linear regulator. The FS8600 operates from an input volta of $V_{OUT}+1V$ to 65V, consumes only 1.8uA quiescent current, and offers 1% initial accuracy and low dropout voltage, 70mV typical at 10mA.

FS8600 is a fixed output LDO with available has available voltages at 3V to 5.0V. Other features include short-circuit protection and thermal shutdown.

FEATURES

- Wide Operating Voltage: $V_{out}+1V$ to 65V (max V_{in} can be up to 80V)
- Ultra Low Quiescent Current : 1.8uA(Typ.)
- Output accuracy: $\pm 2\%$
- High output current: $\geq 200mA$
- Low Dropout Voltages: 70mV@10mA, 700mV@100mA
- System startup with no overshoot
- Short circuit protection is designed with no overshoot
- Excellent power / load transient response
- Low temperature coefficient :100ppm/ $^{\circ}C$
- Packages: SOT23-3

APPLICATIONS

- Battery-powered equipment
- Smoke detector and sensor
- Microcontroller Applications
- Smart electric meter

TYPICAL APPLICATION CIRCUIT

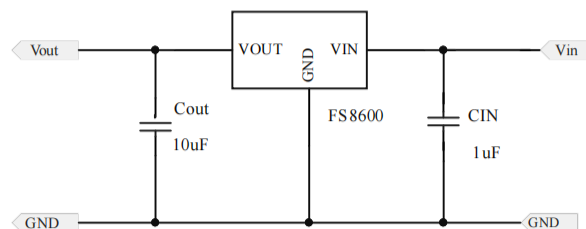



PIN ASSIGNMENT/DESCRIPTION

(TOP VIEW)

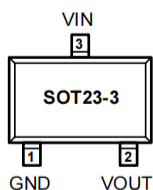

Product Series	Package	Pin Number	Pin Name	Functions
FS8600A <u>XX</u> M	SOT23-3	1	GND	Ground
		2	VOUT	Output
		3	VIN	Input
Marking: 86XX .				

XX: Output Voltage. (FS8600A50M , VOUT:5.0V , FS8600A33M , VOUT:3.3V)

Absolute Maximum Ratings (note)

SYMBOL	ITEMS	VALUE	UNIT
VIN	Input Supply Voltage	80	V
VOUT-GND	Output Voltage TO GND	6	V
Vout - VIN	Output Voltage TO VIN	-75	V
TA	Operating Temperature	-40~105	°C
TJ	Maximum Junction Temperature	150	°C
Tstg	Storage Temperature	-40 to 150	°C
Tsolder	Package Lead Soldering Temperature (10s)	260	°C
θJA	Thermal Resistance,Junction to Ambient	280	°C/W
PD	Power Consumption	446	m/W

Note: Stresses exceeding the range specified under "Absolute Maximum Ratings" may cause substantial damage to the device. Functional operation of this device at other conditions beyond those listed in the specification is not implied and prolonged exposure to extreme conditions may affect device reliability.

RECOMMENDED OPERATING Conditions

SYMBOL	ITEMS	VALUE	UNIT
VIN	VIN Supply Voltage	60	V
TLEAD	Lead Temperature (Soldering) 10 seconds	230	°C
TA	Operating Temperature	-20 to +85	°C



ELECTRICAL CHARACTERISTICS

(TA=25°C, CIN=1μF, VIN=VOUT+1.0V, COUT=10μF, unless otherwise noted)

Parameter	Symbol	Conditions	Min	Typ	Max	Unit
Input Voltage Range	V _{IN}		2.8		60	V
Output Voltage Accuracy	V _{OUT}	I _{OUT} =10mA	-2%		2%	
Quiescent Current	I _Q	V _{IN} =6V~60V		1.8	4	μA
Output Current	I _{OUT}			200		mA
Dropout Voltage	V _{DROP}	I _{OUT} =10mA ΔV _{OUT} = - V _{OUT} *2%		70		mV
		I _{OUT} =100mA ΔV _{OUT} = - V _{OUT} *2%		700		mV
Load Regulation	V _{LR}	1mA ≤ I _{OUT} ≤ 100mA		20		mV
Line Regulation	V _{SR}	I _{OUT} =1mA, V _{IN} =(V _{OUT} +1V) to 30V		0.2		%/V
Power Supply Rejection Ratio	PSRR	V _{in} =12V, I _{out} =10mA F=1Khz, V _{out} =3.3V		70		dB
Current Limit	I _{LIMIT}	V _{IN} =(V _{OUT} +1V) to 60V		400		mA
Thermal Protection	T _{SHDN}			125		°C
Output Voltage Temperature Coefficient	T _{CVOUT}	I _{OUT} =10mA -40°C ≤ T _{AMB} ≤ 100°C		-17		ppm/°C

Functional Block Diagram

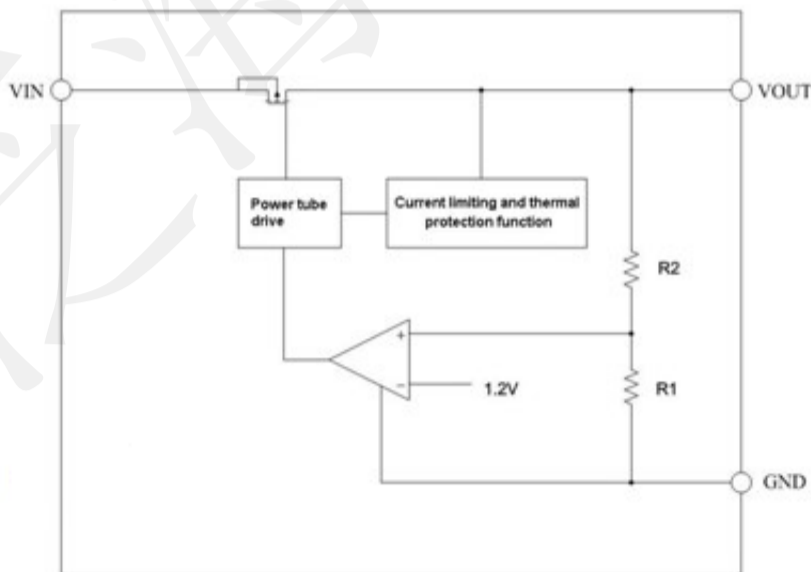



TYPICAL PERFORMANCE CHARACTERISTICS

(TA=25°C, CIN=1uF, VIN=VOUT(3.3V)+1.0V, COUT=10uF, unless otherwise noted)

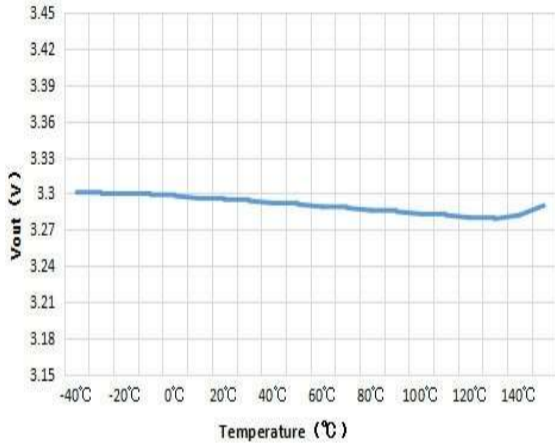

Output Voltage vs Temperature

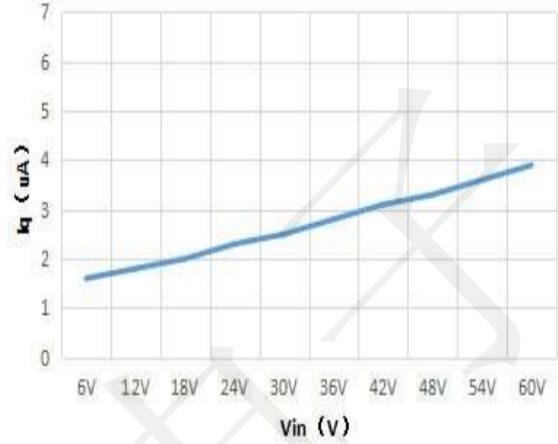

Quiescent current vs Input Voltage

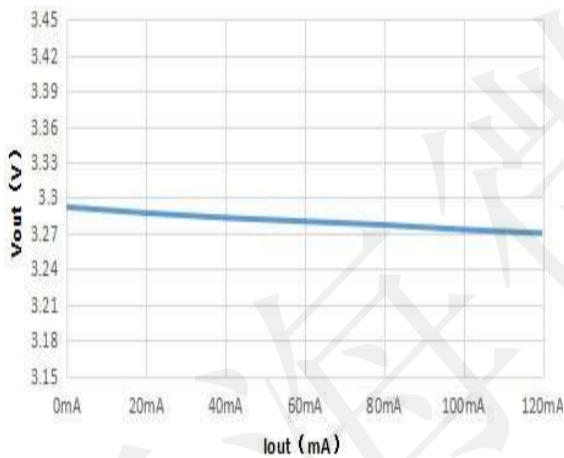

Load Regulation (Vin=30V)



Line Regulation

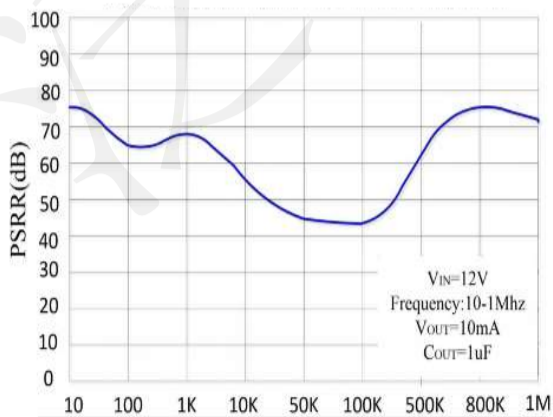

Power-Supply Rejection Ratio vs Frequency

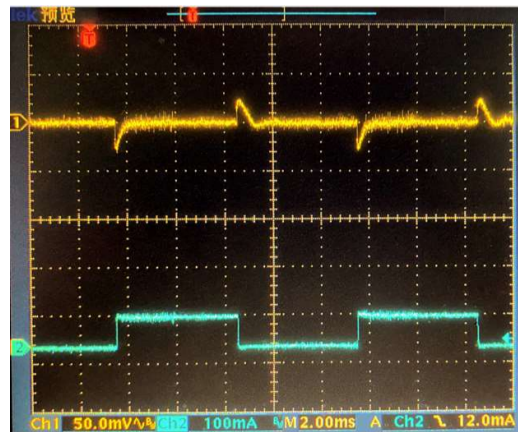

Load Transient (Vin=12V) 10mA~100mA

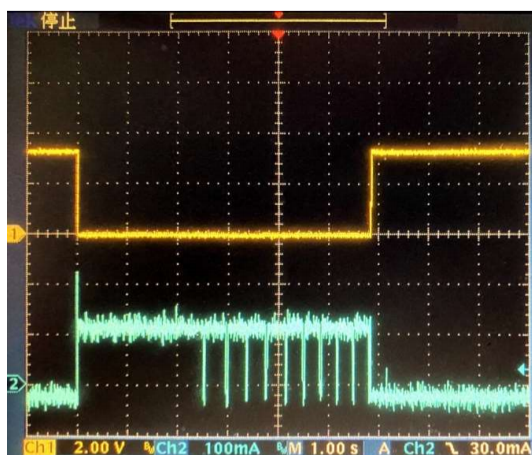

Short-Circuit and OTP (Vin=24V)

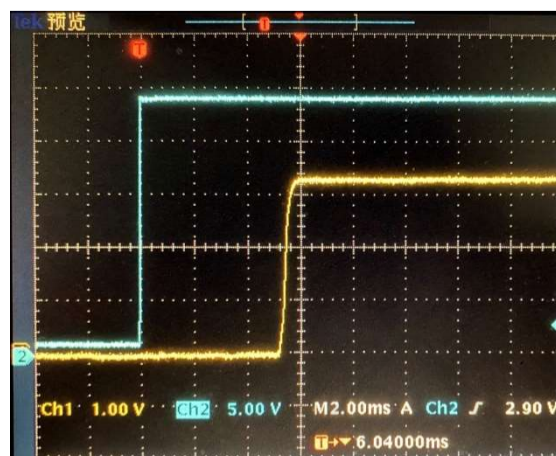

VCC Power ON

APPLICATION INFORMATION

INPUT CAPACITOR

An input capacitor of $1\mu\text{F}$ is required between the VIN and GND pin. The capacitor shall be placed as close as possible to VIN pin, and the wide copper trace is also recommended.

OUTPUT CAPACITOR

The recommended is $10\mu\text{F}$ ceramic capacitor. The minimum capacitance for stable and correct operation is $1\mu\text{F}$. The higher the value of this output capacitor, the lower the ripple during the operations. The output capacitor should be placed as close to the Output Pin as possible. The wide copper trace is recommended.

NO-LOAD STABILITY

The FS8600 will remain stable and in regulation with no external load.

FOLD-BACK SHORT-CIRCUIT PROTECTION

When short-circuit occurs, FS8600 will fold back the short-circuit currents to a pre-determined lower level, This will reduce excessive heat in otherwise large current conditions. This feature provides another level of protection to IC itself and also the whole system.

IN-RUSH CURRENT AND VOLTAGE

The following figure shows a typical application circuit for the FS8600 devices. Please keep in mind that in-rush current can push up the Vin overshoot by as much as 50%. For example, when $V_{in}=50\text{V}$, the in-rush caused spike voltage can be as high as 75V . Therefore the voltage rating of C_{in} needs to be higher than 50% of the application.

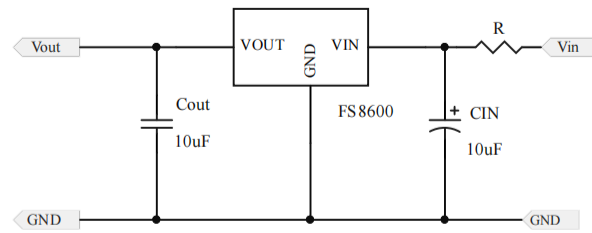

In live insertion application, it is suggested that R, CIN are selected as following

1. $C_{IN}=10\mu\text{F} \sim 100\mu\text{F}$ ceramic or electrolytic capacitor with maximum voltage greater than 80V, $R=0$;
2. $C_{IN}=1\mu\text{F} \sim 10\mu\text{F}$ ceramic or electrolytic with maximum voltage greater than 80V and $R=2\Omega$ in the type of 1206.

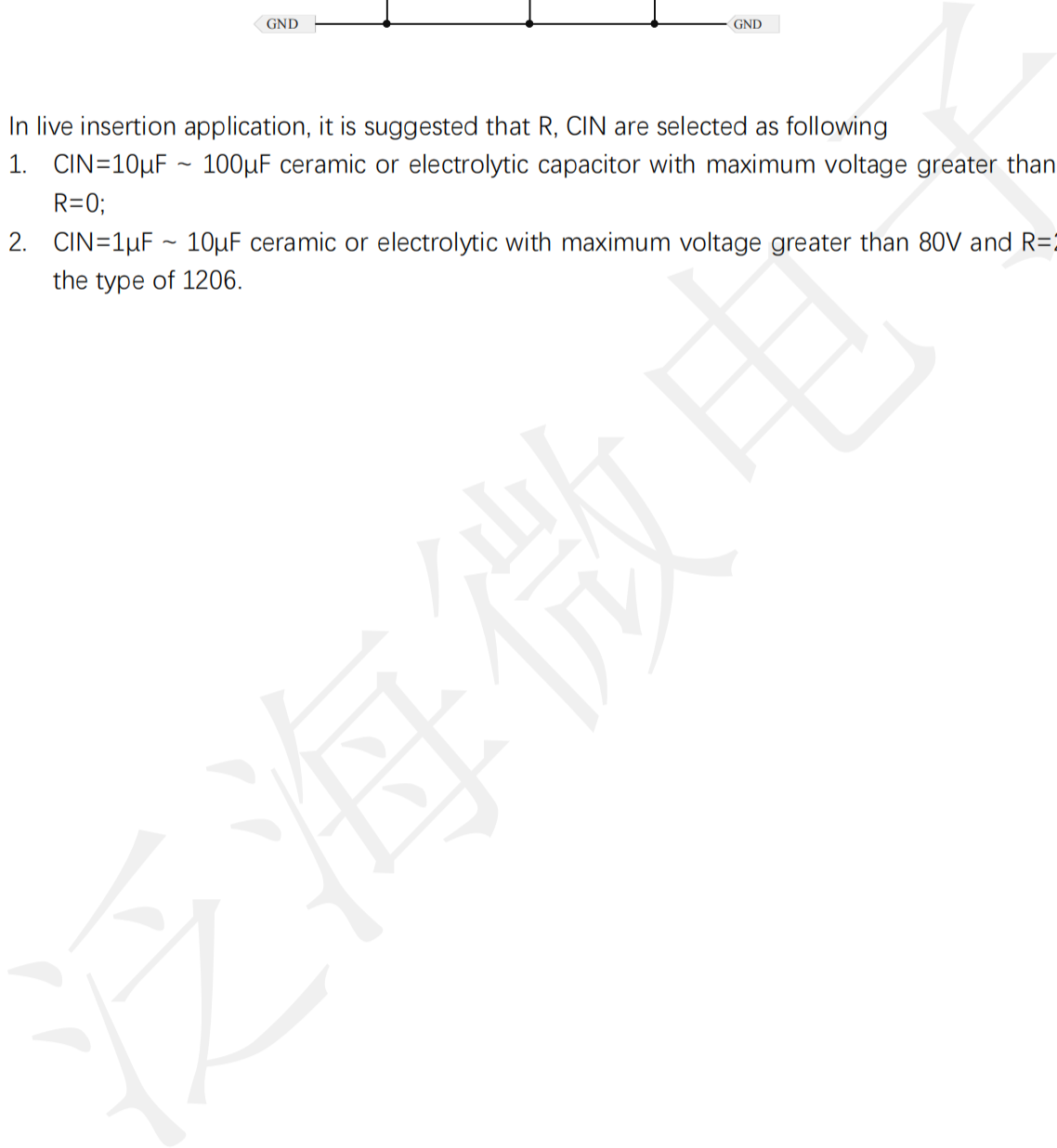



PACKAGE DESCRIPTION

SOT23-3

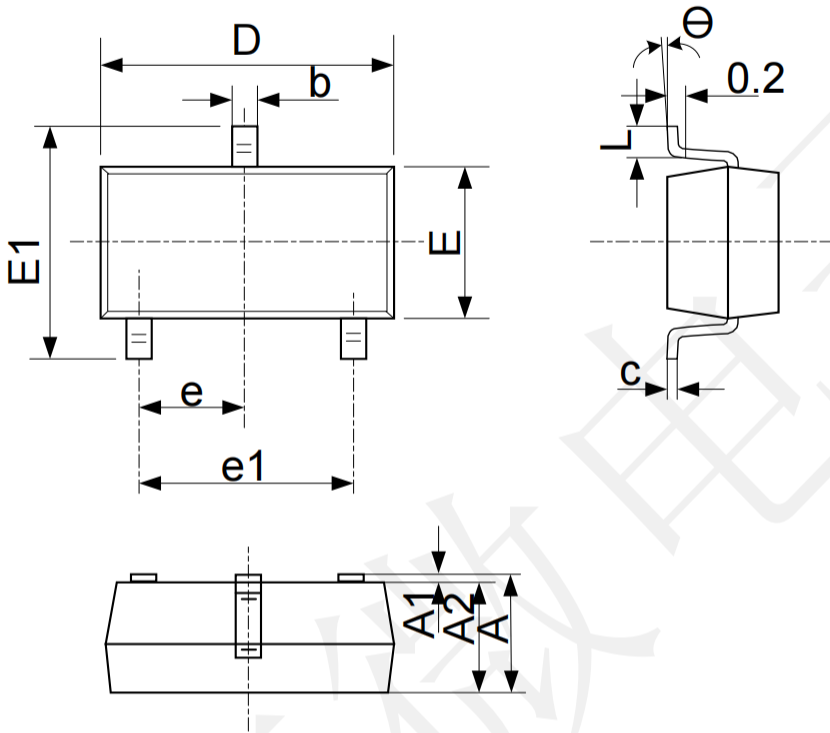

Symbol	Dimensions In Millimeters		Dimensions In Inches	
	Min	Max	Min	Max
A	1.050	1.250	0.041	0.049
A1	0.000	0.100	0.000	0.004
A2	1.050	1.150	0.041	0.045
b	0.300	0.500	0.012	0.020
c	0.100	0.200	0.004	0.008
D	2.820	3.020	0.111	0.119
E	1.500	1.700	0.059	0.067
E1	2.650	2.950	0.104	0.116
e	0.950(BSC)		0.037(BSC)	
e1	1.800	2.000	0.071	0.079
L	0.300	0.600	0.012	0.024
θ	0°C	8°C	0°C	8°C