



概述

FS2117是一颗高效同步整流升压芯片，IC内部集成低阻抗功率MOS管。具有短路保护功能。内部集成软启动电路，无需外部补偿电容，外部反馈网络。输入 3.6V，输出5V，输出电流 2.4A 时效率可达 91%。FS2117 为移动电源等高效升压应用领域提供了新的解决方案。

特点

- 工作频率 500kHz
- 内部集成同步整流 MOS，无需外部整流二极管
- 外部反馈网络，输出电压可调节
- 恒流短路保护模式
- 电流模式，响应速度快
- 内部过流保护功能

应用

- 锂电池供电
- 智能手机
- 平板电脑等智能充电领域

典型应用电路

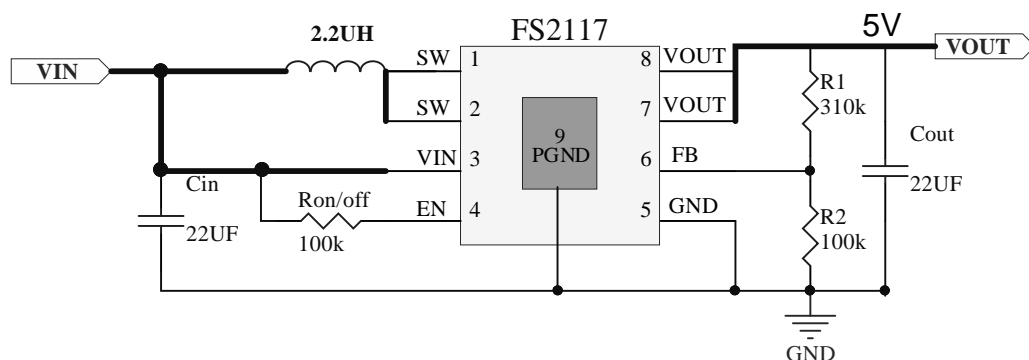



引脚定义

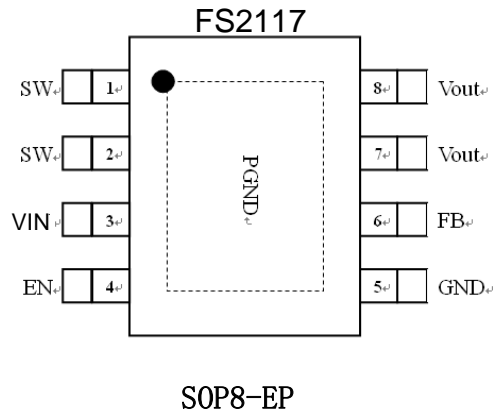

效率图

输入 3.6V, 输出电压 5.0V, 输出电流 2.4A 时效率可达 90%.

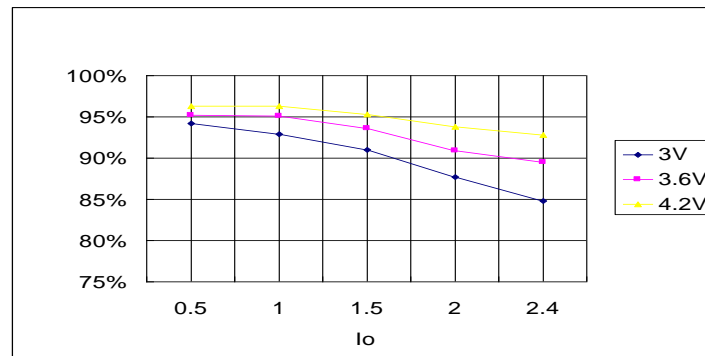

引脚描述

NO.	Pin Name	Pin Function Description
1	SW	Converter Switch Pin. Connect inductor here.
2	SW	Converter Switch Pin. Connect inductor here.
3	VIN	Converter Supply Voltage.
4	EN	Device Enable Control Input.
5	GND	Ground.
6	FB	Converter Feedback Input.
7	VOUT	Converter Output and IC Supply Voltage
8	VOUT	Converter Output and IC Supply Voltage



Functional Block Diagram

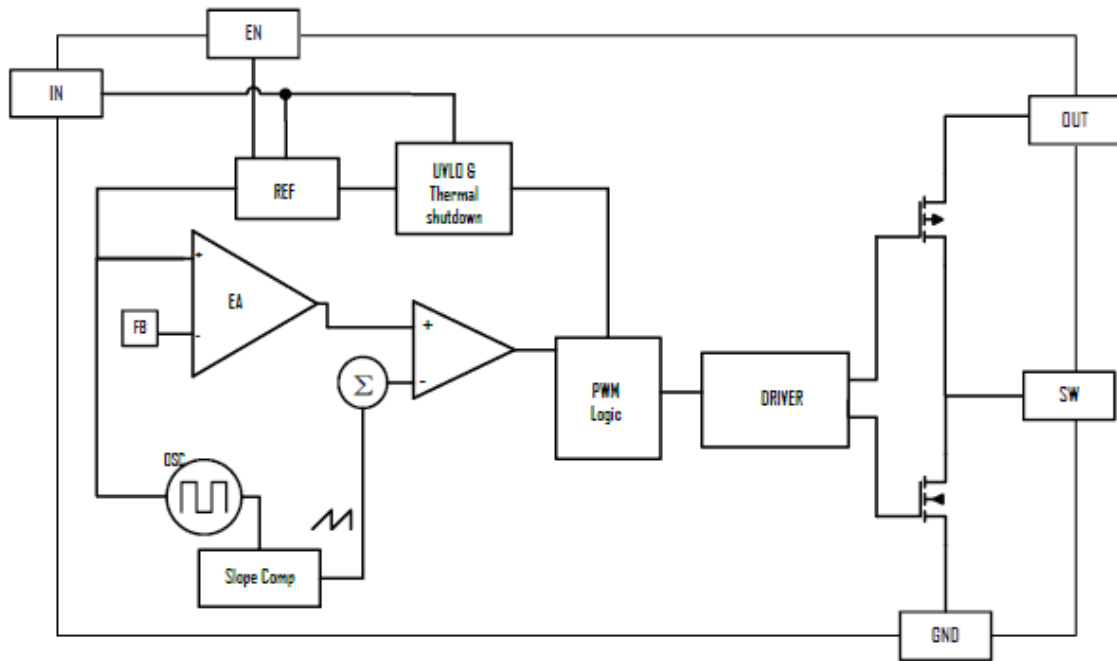

Absolute Maximum Ratings

Symbol	Parameter	Maximum	Units
SW	SW Pin Voltage	6	V
VIN	VIN Pin Voltage	6	V
FB	FB Pin Current	6	V
VOUT	VOUT Pin Current	6	V

Recommended Operating Conditions

Symbol	Parameter	Maximum	Units
T _J	Operating Junction Temperature	-20 to 125	°C
T _A	Operating Ambient Temperature	-20 to 85	°C
T _s	Storage Temperature	-65 to 150	°C
	Lead Temperature (less than 15 seconds)	260	°C



Electrical Characteristics

($V_{out}=5.0V$, $V_{in}=3.6V$, $L=2.2\ \mu H$, $C_{in}=47\ \mu F$, $C_{out}=47\ \mu F$; $T_j=25^\circ C$ unless otherwise specified)

Symbol	Parameter	Test Conditions	Min	Typ	Max	Unit
VIN	VIN Pin Voltage		2.5		4.2	V
Vout	Output Voltage				5.2	V
Ivin	Input Quiescent current	Vin=3.6V FB=2V No load, no switch			250	μA
Ivin(SHUNT)	Shutdown supply current	EN=0			5	μA
Fosc	Switch Frequency			0.5		MHZ
SS	Soft-start			2		ms
VFB	FB Regulation Voltage		1.22	1.245	1.269	V
IFB	FB input current	VFB=1V			100	nA
IShort	Short circuit Current	Vin=3.6V Vout=0V		200		mA
DMAX	Maximum Duty Cycle	FB=0.95V		90		%
I _{pvout_sw}	VOUT Leakage Current	Vout=5V EN=0			5	μA
ISW	SW Leakage Current	Vout=5V EN=0			5	μA
Switch ON Resistance	Ron-N			39		m Ω
	Ron-P			42		m Ω
Ilim	Peak Current Limit	EN=1		6.5		A
Efficiency	EN=1 Vin=3V Vout=5V Iout =2A			87		%
VSCP	Vout Short-Circuit Threshold	Falling Edge		Vout=Vin		V
VSCP	Vout Short-Circuit Threshold	Rising Edge		80%Vin		V
Vuvlo	Vin uvlo Threshold	Falling Edge		2.5		V
Vuvlo	Vin uvlo Threshold	Rising Edge		2.7		V
Temp	Thermal Shutdown Threshold	Rising Edge		150		$^\circ C$
EN	EN input High Level		0.76		5	V
EN	EN input Low Level		0		0.72	V

**功能描述:**

FS2117 是一颗电流模式高效同步升压转换芯片。采用固定频率 500kHz, 脉冲宽度调节控制模式调节输出电压。内置高边功率 Mos 导通电阻低至 42mΩ, 低边功率 Mos 导通电阻低至 39mΩ。为用户在锂电池供电, 5V 输出领域提供高效解决方案。

软启动电路:

FS2117 内部集成软启动功能和恒流启动模式, 当输出电压低于输入电压时限制高边功率 Mos 电流, 缓慢对输出电容充电限制输出电压过冲。当输出电压高于输入电压时, 采用软启动模式, 限制占空比使输出电压在可控范围内, 防止输出电压过高, 损坏芯片。

短路保护:

当输出电压低于输入电压的 80%时, 进入短路保护状态, 限制高边功率 Mos 输出电流。相比于打嗝短路保护模式, 只限制平均电流的做法, 直接限制高边功率 Mos 输出电流的短路保护模式, 即限制了平均电流, 也限制了峰值电流, 对锂电池和芯片进行了更完善的保护, 减小损坏风险。

输出电压调节:

FS2117 通过外部分压电阻可以调节输出电压, FB 电压典型值 1.245V。输出电压可根据以下公式计算:

$$V_{out} = 1.245 \cdot \left(\frac{R_1}{R_2} + 1 \right)$$



Layout 注意事项:

1. 大电流路径（输入、GND、SW）铺铜需要尽可能短、宽，直接相连
2. 铺铜 SW 路径时，路径需要短、宽以减小 EMI
3. 输入电容尽量靠近芯片的 VIN 端使芯片的输入端，减小输入纹波,C1,C2 选择贴片电容
4. 输出反馈电阻 R1、R2 直接连接到 FB 端，R2 尽可能连接到输出点，减小铺铜电阻对输出电压的影响

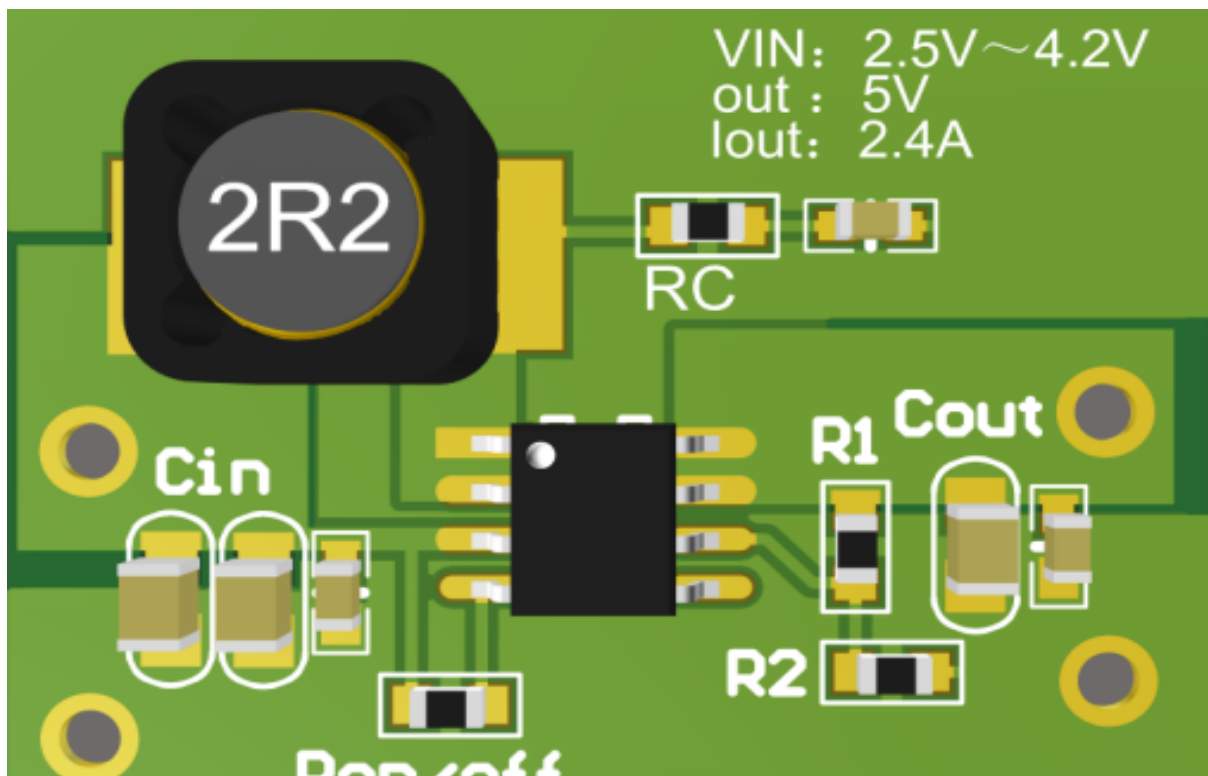



OUTLINE DRAWING

SOP8:

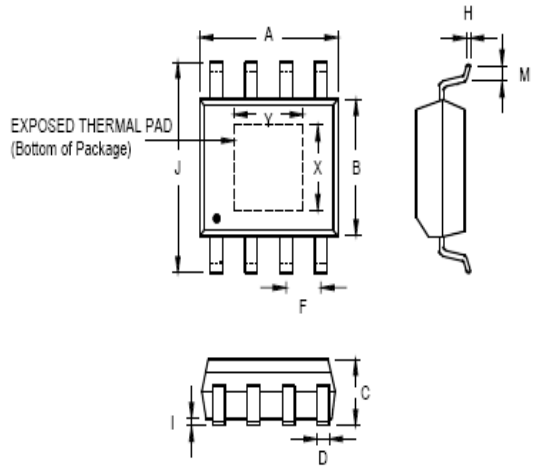

Symbol	Dimensions In Millimeters		Dimensions In Inches	
	Min	Max	Min	Max
A	4.801	5.004	0.189	0.197
B	3.810	3.988	0.150	0.157
C	1.346	1.753	0.053	0.069
D	0.330	0.508	0.013	0.020
F	1.194	1.346	0.047	0.053
H	0.191	0.254	0.008	0.010
I	0.000	0.152	0.000	0.006
J	5.791	6.198	0.228	0.244
M	0.406	1.270	0.016	0.050
X	2.057	2.515	0.081	0.099
Y	2.057	3.404	0.081	0.134