



GENERAL DESCRIPTION

The FS4070 is a highly integrated synchronous switch-mode Li-Ion Battery Charger. With few external components, FS4070 is well suited for a wide range of portable applications. Charging current can be programmed by an external current sensing resistor.

With 720KHz switching frequency, FS4070 can use of small external components. Other features include UVLO, automatic recharge, charge status indicators and battery temperature monitor.

FEATURES

- 92% Efficiency
- 3.5A Adjustable Charge Current
- Fixed Frequency Operation at 720kHz
- Input Voltage Regulation
- Automatic Recharge
- Battery Over-Temperature Protection
- Battery Short and Thermal Protection
- Over-Voltage
- Over-Charge Current

APPLICATIONS

- Portable Information Appliances
- Charging Docks & Cradles

TYPICAL APPLICATION CIRCUIT

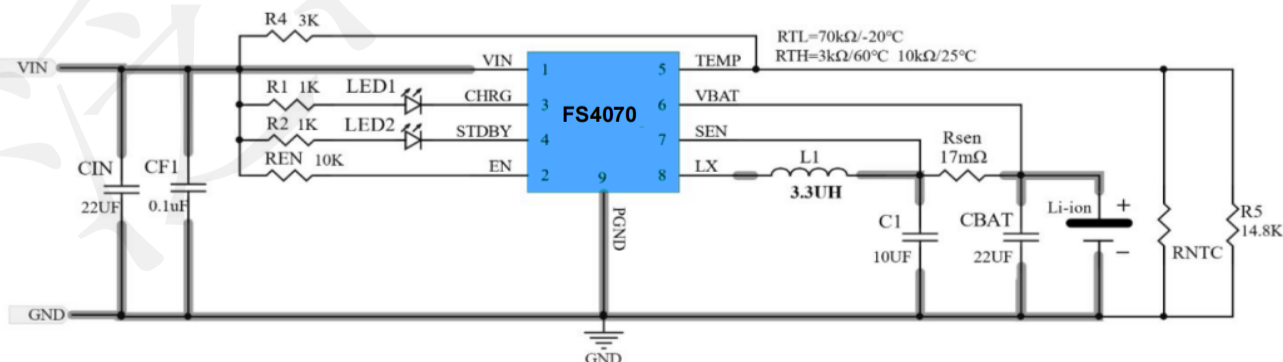

NOTE:

1. For applications that do not need to monitor the battery temperature, short the TEMP pin to GND.
2. $R_{sen} = 50mV \div I_{CHG}$



Function Block Diagram

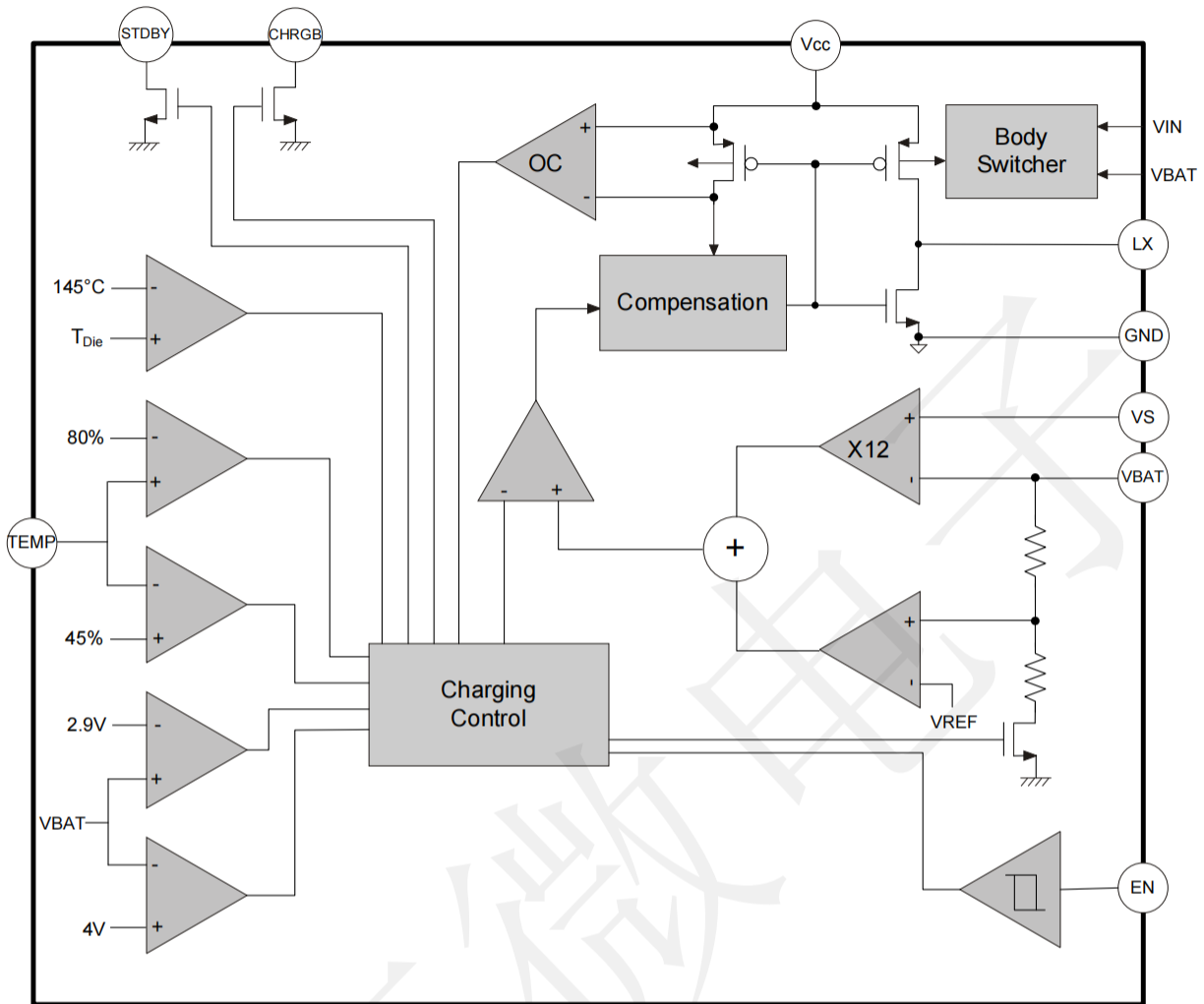

Charge Status Indicators

Charge Status	CHRGB (Red)	STDBY (Green)
In Charging	ON	OFF
Charge Termination	OFF	ON
UVLO, OverT, UnderT, NoBat(with TEMP used)	OFF	OFF



State Diagram

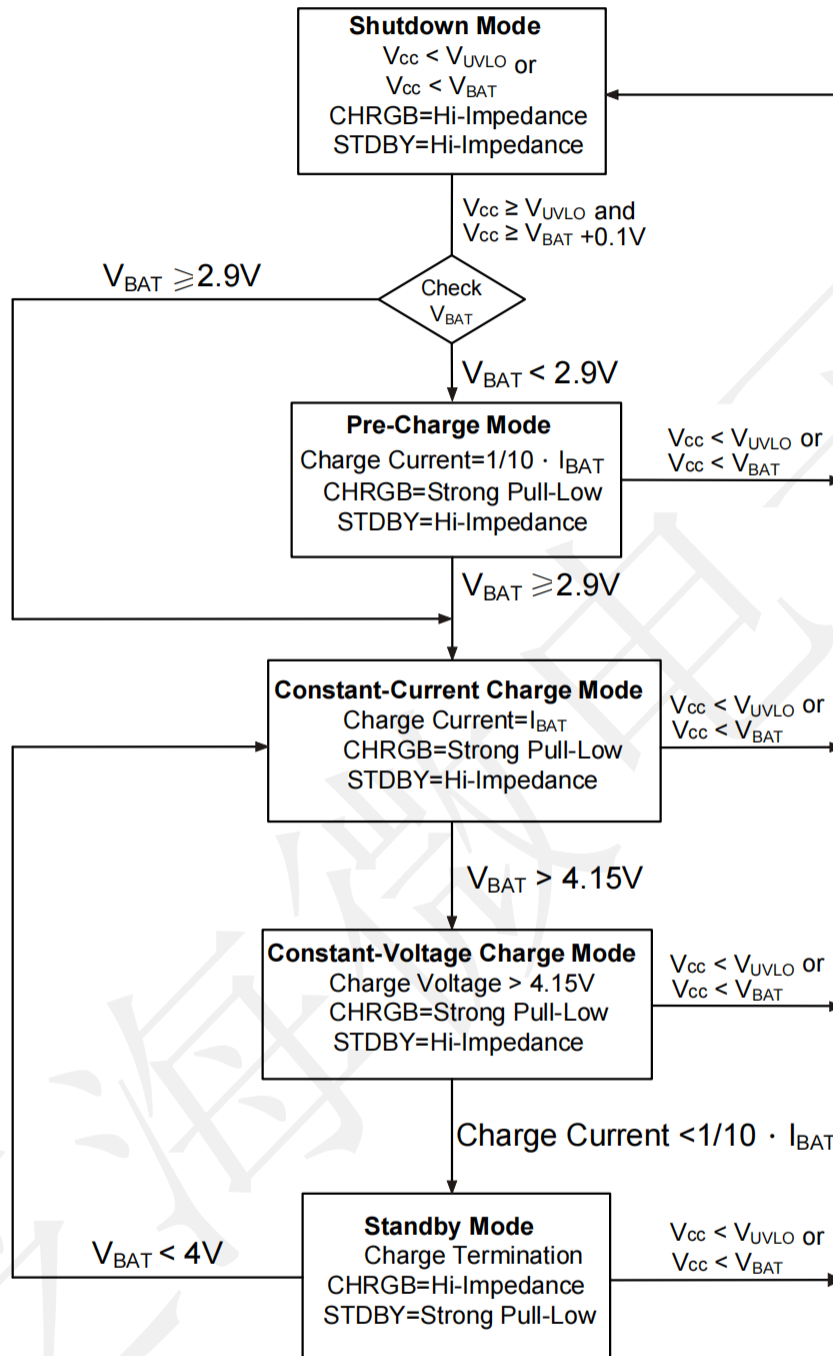



Typical Charging Profile

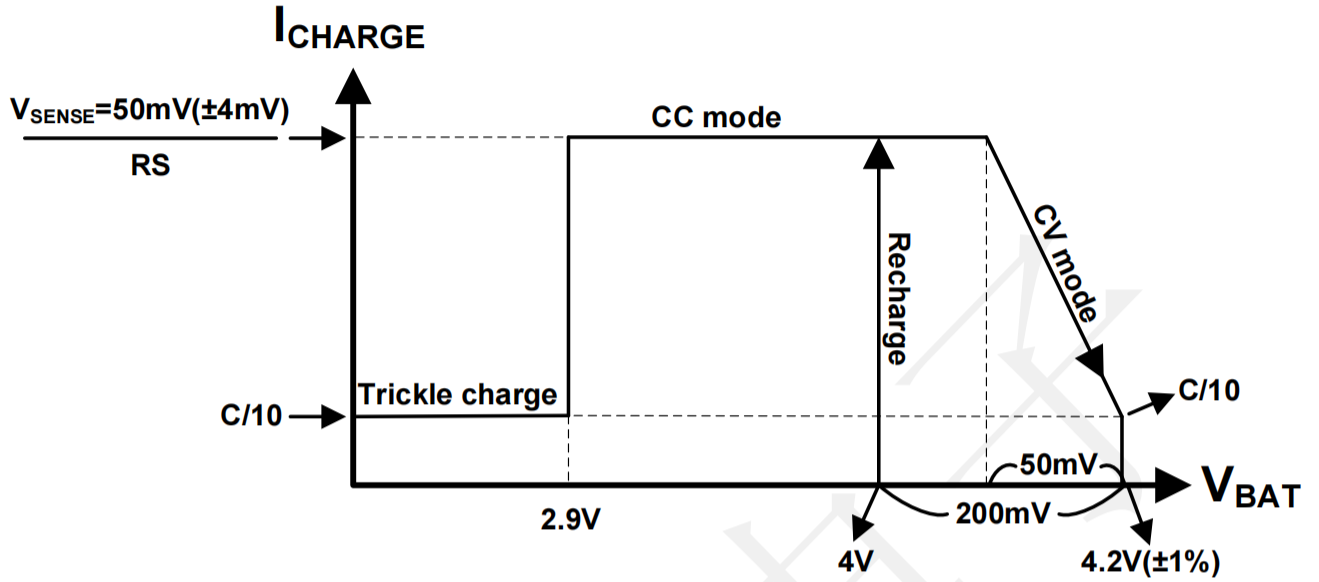

Input Voltage Regulation Descriptions

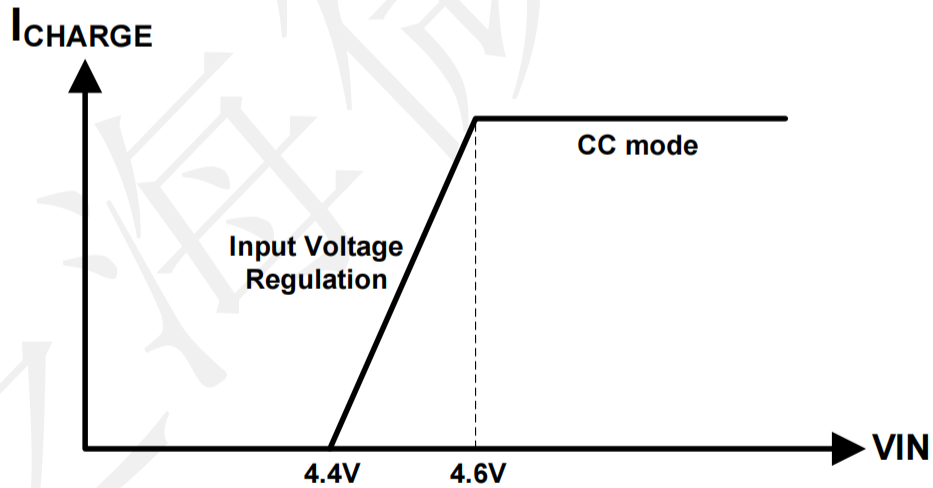



Pin Descriptions

SOP-8L (EP)

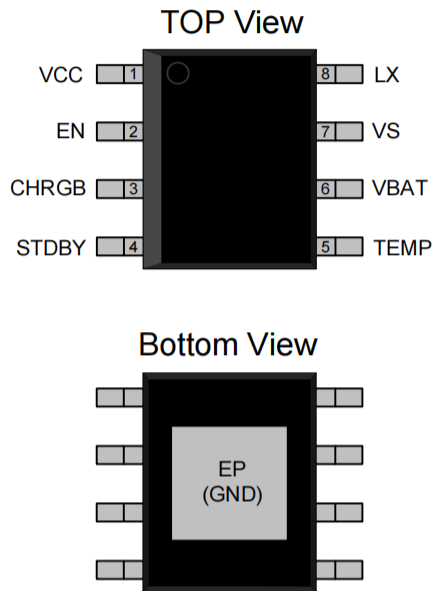

Name	No.	I / O	Description
VCC	1	P	Supply Voltage
EN	2	I	Enable Control
CHRGB	3	O	Charge State Indicator1
STDBY	4	O	Charge State Indicator2
TEMP	5	I	Battery Temperature Detector
VBAT	6	P	Battery Voltage
VS	7	I	Charge current-sense input
LX	8	I	Switch node and inductor connection pin
EP	9	P	Exposed PAD-Must connect to Ground



Ordering Information

Part Number	Operating Temperature	Package	MOQ	Description
FS4070	-25°C ~ +85°C	SOP-8L(EP)	2500EA	Tape & Reel

Absolute Maximum Ratings

Parameter	Symbol	Conditions	Min.	Typ.	Max.	Unit
Supply Voltage	V _{CC}		-0.3		6	V
LX to VCC Voltage	V _{DS}				-7	V
LX Voltage	V _{LX}		-0.3		7	V
All Other Pins			-0.3		6	V
BAT Current	I _{BAT}				4.5	A
Junction Temperature	T _J				+150	°C
Storage Temperature	T _S		-65		+150	°C
Thermal Resistance (Junction to Ambient)	θ _{JA}	SOP-8L			60	°C / W
Thermal Resistance (Junction to Case)	θ _{JC}	SOP-8L			10	°C / W
Operating Temperature			-25		+85	°C
Lead Temperature (soldering, 10 sec)					+260	°C

Suggested IR Re-flow Soldering Curve

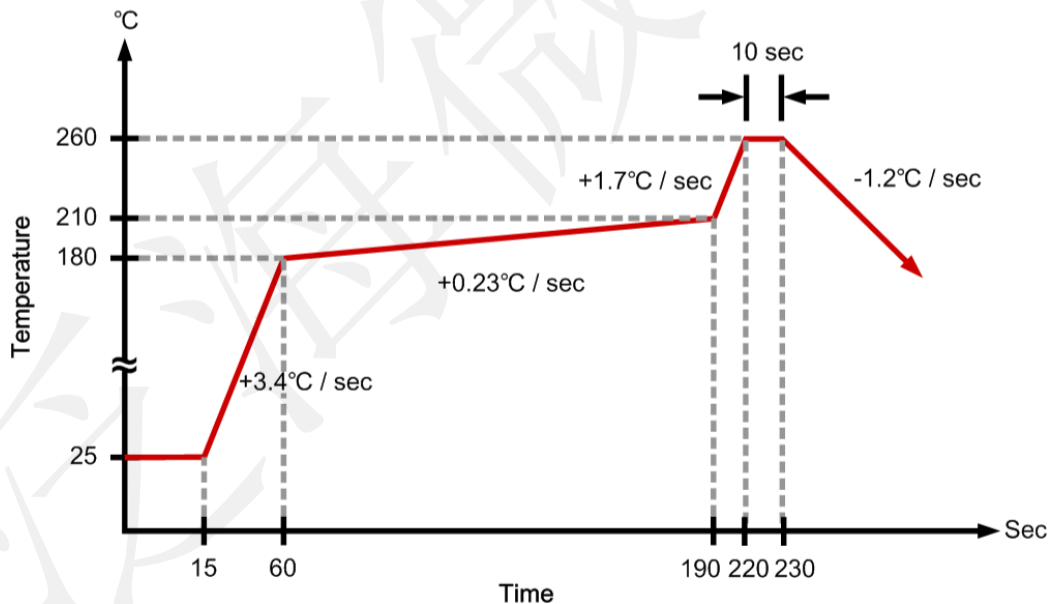



Recommended Operating Conditions

Parameter	Symbol	Conditions	Min.	Typ.	Max.	Unit
Supply Voltage	V _{CC}		4.8		5.5	V
Operating Temperature		Ambient Temperature	-25		85	°C

DC Electrical Characteristics (V_{CC}=5V, T_A= 25°C, unless otherwise noted)

Parameter	Symbol	Test Conditions	Min.	Typ.	Max.	Unit
Standby Current	I _{SB}	Charge Termination		300	500	μA
Shutdown Supply Current	I _{ST}	V _{CC} < V _{BAT} , V _{EN} = 0V			200	μA
CV Output (Float) Voltage	V _{FLOAT}	0°C < T _A < 85°C	4.158	4.200	4.242	V
BAT pin Current	I _{BAT}	Standby-Mode, V _{BAT} =4.2V		5	10	μA
		Shutdown-Mode,		5	10	μA
		Sleep-Mode, V _{CC} =0V		1	10	μA
Current Sense Reference Voltage	V _{SENSE}		46	50	54	mV
Trickle Charge Current	I _{TRIKL}	V _{BAT} < V _{TRIKL} , R _{Sense} = 16.66mΩ		300		mA
Trickle Charge Threshold Voltage	V _{TRIKL}	R _{Sense} = 16.66mΩ, V _{BAT} Rising	2.8	2.9	3.0	V
Trickle Charge Hysteresis Voltage	V _{TRKHYS}	R _{Sense} = 16.66mΩ		200		mV
V _{CC} Under Voltage Lockout Threshold	V _{UV}	V _{CC} Rising	4.32	4.5	4.68	V
V _{CC} Under Voltage Lockout Threshold Hysteresis	V _{UVHYS}			200		mV
V _{CC} -V _{BAT} Lockout Threshold	V _{ASD}	V _{CC} Rising		100		mV
		V _{CC} Falling		10		mV
PMOSFET On Resistance	R _{ON(PMOS)}			50		mΩ
NMOSFET On Resistance	R _{ON(NMOS)}			50		mΩ
C/10 Termination Current Threshold	I _{TERM}	R _{Sense} = 16.66mΩ		300		mA
		R _{Sense} = 50mΩ		100		mA
Switching Frequency	F _{SW}		580	720	860	KHz
Max. Duty	D _{MAX}			98		%
Min. Duty	D _{MIN}		10			%
CHRGB pin Output Low Voltage	V _{CHRGB}	I _{CHRGB} = 5mA		0.3	0.6	V
STDBYB pin Output Low Voltage	V _{STDBY}	I _{STDBY} = 5mA		0.3	0.6	V
Battery Recharge Threshold Voltage	V _{RECHRG}	V _{FLOAT} - V _{RECHRG}		200		mV
Thermal Shutdown	T _{LIM}			150		°C
TEMP pin High Threshold Voltage	V _{TEMP-H}		76	80	83	%
TEMP pin Low Threshold Voltage	V _{TEMP-L}		42	45	48	%
EN Input High Voltage	V _{EN-H}		2.5			V
EN Input Low Voltage	V _{EN-L}				0.5	V



Typical Operating Characteristics

($V_{IN}=5V$, $V_{BAT}=3.7V$ $T_A= 25^{\circ}C$, unless otherwise noted)

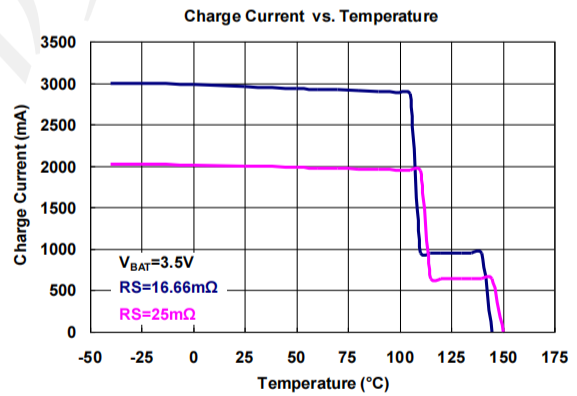
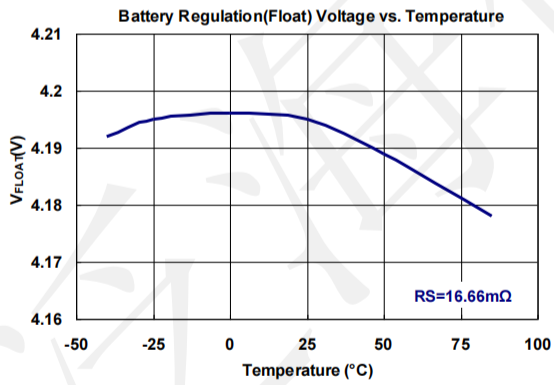
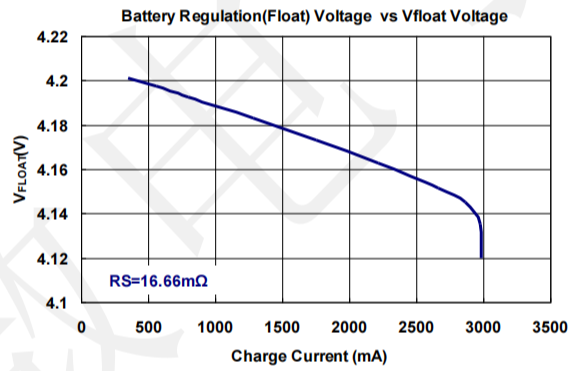
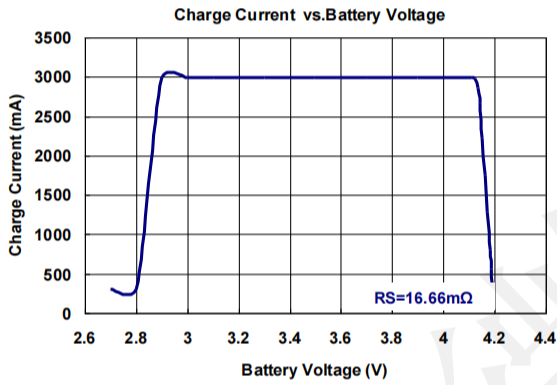
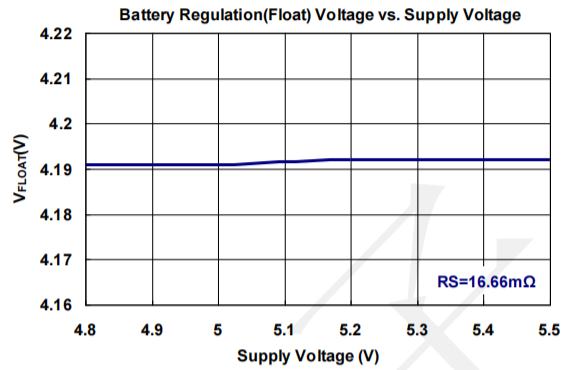
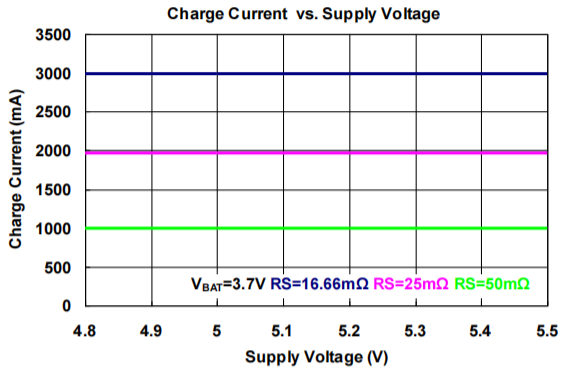



Power ON Test

($V_{IN}=5V$, $V_{BAT}=3.5V$, $I_{BAT}=3A$)

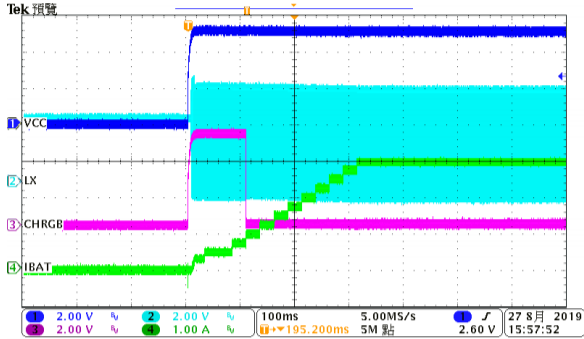

Power OFF Test

($V_{IN}=5V$, $V_{BAT}=3.5V$, $I_{BAT}=3A$)

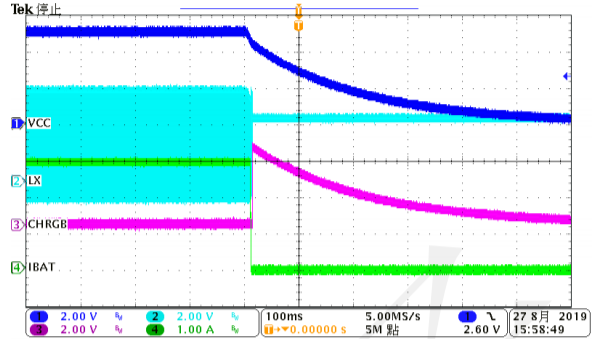

EN ON Test

($V_{IN}=5V$, $V_{BAT}=3.5V$, $I_{BAT}=3A$)

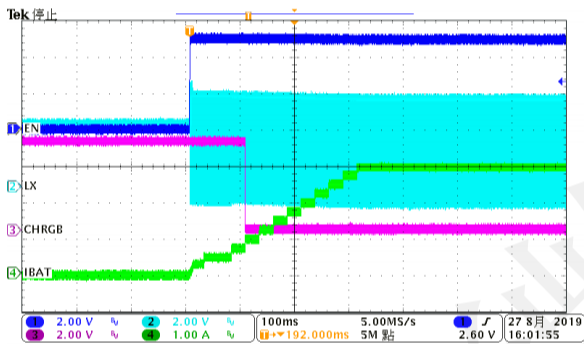

EN OFF Test

($V_{IN}=5V$, $V_{BAT}=3.5V$, $I_{BAT}=3A$)

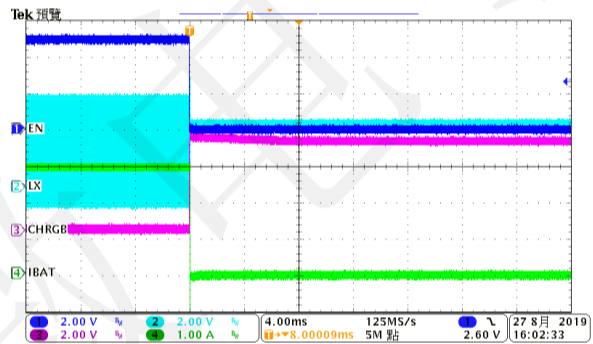

The Charge Cycle End

($V_{IN}=5V$, $I_{BAT}=3A$)

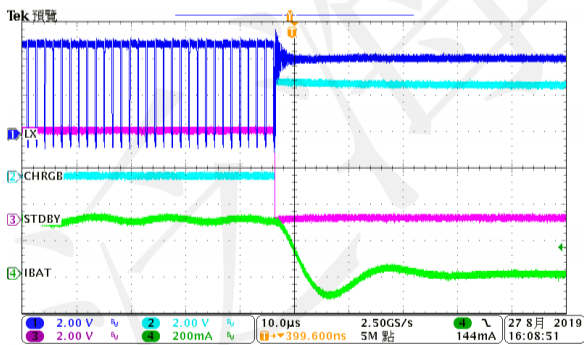

Battery Short

($V_{IN}=5V$, $I_{BAT}=3A$)

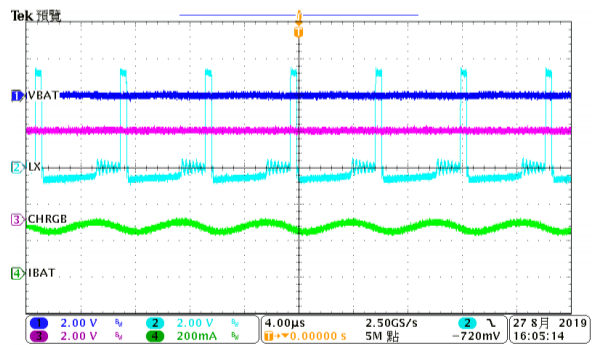



Function Description

Operation

The FS4070 is a switch-mode battery charger designed primarily for charging single cell lithium-ion batteries. The charger uses a constant-current/constant-voltage charge algorithm with programmable current. Charging current can be programmed externally with a single current sensing resistor between the VS pin and the BAT pin. The final battery float voltage is internally set to 4.2V.

Normal Charge Cycle

A charge cycle begins when the voltage at the VCC pin rises above the UVLO threshold. If the BAT pin voltage is smaller than 2.9V, the charger enters trickle charge mode. In this mode, the FS4070 supplies approximately 1/10 the programmed charging current to bring the battery voltage up to a safe level for full current charging. When the BAT pin voltage rises above 2.9V, the charger enters constant-current mode, where the full programmed charge current is supplied to the battery. When the BAT pin voltage approaches 4.15V, the FS4070 enters the constant-voltage mode and the charge current begins to decrease. When the charge current drops to 1/10 of the programmed value, the charge cycle ends.

Charge Current Programming

When the battery voltage exceeds the trickle charge threshold, the charger goes into the full scale constant current charge mode. In constant current mode, the charge current is set by the external sense resistor RS and an internal 50mV reference. The required resistor value can be calculated from the charge current with following equation:

$$RS = \frac{50mV}{I_{CHG}}$$

Charge Termination

A charge cycle is terminated when the charge current falls to 1/10 the programmed value after the final float voltage is reached. This condition is detected by using an internal filtered comparator to monitor the sense voltage. When the voltage between the VS pin and the BAT pin falls below 10mV for longer than T_{TERM} (1.8ms), charging is terminated. The charge current is latched off and the FS4070 enters standby mode, where the input supply current drops to 300uA. The FS4070 draws no current from the battery in standby mode. This feature reduces the charge and discharge cycles on the battery, further prolonging the battery life.



Thermal Protection

An internal thermal feedback loop reduces the setting charge current to 1/3, if the die temperature rises above a preset value of approximately 125°C. This feature protects the FS4070 from excessive temperature and allows the user to push the limits of the power handling capability of a given circuit board without risk of damaging the FS4070. The charge current can be set according to typical ambient temperature with the assurance that the charge will automatically reduce the current in worst case condition.

The FS4070 will shutdown automatically when the internal junction temperature reaches 150°C to protect both the part and the system. The power MOSFET wake up when the junction temperature drops 50°C under the OTP threshold temperature.

Battery Temperature Fault Monitoring

In the event of a battery over-temperature condition, the charging control will turn off the internal pass device and report a battery temperature fault on the TEMP pin. Inside the FS4070, two internal voltage references V_{TEMP-H} and V_{TEMP-L} are fixed at 80% $\times V_{CC}$ and 45% $\times V_{CC}$ respectively. As the TEMP pin voltage rises above V_{TEMP-H} or falls below V_{TEMP-L} , the FS4070 stops charging and indicates a fault condition. After the system recovers from a temperature fault, the device will resume charging operation. For applications that do not need to monitor the battery temperature, short the TEMP pin to the GND.

The values of R4 and R5 are set according to the battery temperature range and the value of thermal sensitive resistor. If the battery is equipped with NTC (Negative Temperature Coefficient) thermistor and the temperature monitor range is $T_L \sim T_H$ ($T_L < T_H$), then R_T , the thermistor resistance, decreases as temperature increases from T_L to T_H , means $R_{TL} > R_{TH}$.

The TEMP pin voltage can be calculated as:

$$V_{TEMP} = \frac{R5 // R_T}{R4 + R5 // R_T} \times V_{CC}$$

Thus, this V_{TEMP} decreases as the temperature increase from T_L to T_H .

To set proper R4 and R5 value for temperature protection, we set:

$$0.8 \times V_{CC} = V_{TEMPH} = \frac{R5 // R_{TL}}{R4 + R5 // R_{TL}} \times V_{CC} \text{ at } T_L$$

$$0.45 \times V_{CC} = V_{TEMPL} = \frac{R5 // R_{TH}}{R4 + R5 // R_{TH}} \times V_{CC} \text{ at } T_H$$



Where R_{TL} and R_{TH} are the thermistor resistances at T_L and T_H respectively.

So R4 and R5 can be derived as following:

$$R4 = \frac{R_{TL}R_{TH}(K_2 - K_1)}{(R_{TL} - R_{TH})K_1 K_2} = \frac{R_{TL}R_{TH} \times 35}{(R_{TL} - R_{TH}) \times 36}$$

$$R5 = \frac{R_{TL}R_{TH}(K_2 - K_1)}{R_{TL}(K_1 - K_1K_2) - R_{TH}(K_2 - K_1K_2)} = \frac{R_{TL}R_{TH} \times 35}{R_{TL} \times 9 - R_{TH} \times 44}$$

where $K_1=0.45$ and $K_2=0.8$

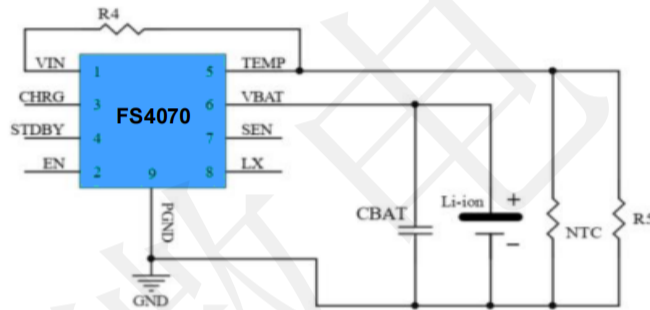

Under Voltage Lockout (UVLO)

An internal under voltage lockout circuit monitors the input voltage and keeps the charger in shutdown mode until V_{cc} rises above the under voltage lockout threshold. The UVLO circuit has a built-in hysteresis of 200mV. Furthermore, to protect against reverse current in the power MOSFET, the UVLO circuit keeps the charge in shutdown mode if V_{cc} falls to within 10mV of the battery voltage. If the UVLO comparator is tripped, the charger will not come out of shutdown mode until V_{cc} raises 100mV above the battery voltage.

Short Circuit Protection (SCP)

When Battery voltage is lower than the short circuit protection threshold, the Hiccup mode is active and average current is around 50mA to assure opening the battery protective plate. Normal operation mode recovers after fault condition is removed.



Manual shutdown

At any point in the charge cycle, the FS4070 can be put into shutdown mode when put the EN pin to the low-level voltage. This reduces the battery drain current to about 10uA and the supply current to less than 200uA.

Automatic Recharge

Once the charge cycle is terminated, the FS4070 continuously monitors the voltage on the BAT pin using a comparator with a 1.8ms filter time ($T_{RECHARGE}$). A charge cycle restarts when the battery voltage falls below 4V (which corresponds to approximately 80% to 90% battery capacity). This ensures that the battery is kept at or near a fully charged condition and eliminated the need for periodic charge cycle initiations. CHRGB pin output enters a strong pull-down state during recharge cycles.



Application Information

Inductor Selection

Inductance value is decided based on different condition. 3.3uH to 4.7uH inductance value is recommended for general application circuit. There are three important inductor specifications, DC resistance, saturation current and core loss. Low DC resistance has better power efficiency.

Capacitor Selection

Use Low ESR capacitors are preferred to reduce the input inrush voltage, Ceramic capacitor of X5R and X7R are recommended, which have low equivalent series resistance (ESR) and wider operation temperature range.

Layout Considerations

1. The power traces, consisting of the GND trace, the LX trace and the battery trace should be kept short, direct and wide.
2. Layout switching node LX, inductor and diode connection traces wide and short to reduce EMI.
3. Place C_{IN} nearby V_{CC} pin as closely as possible to maintain input voltage steady and filter out the pulsing input current.
4. The GND of the C_{IN} and C_{OUT} should be connected close together and directly to a ground plane.
5. Place RS nearby BAT pin and VS pin.

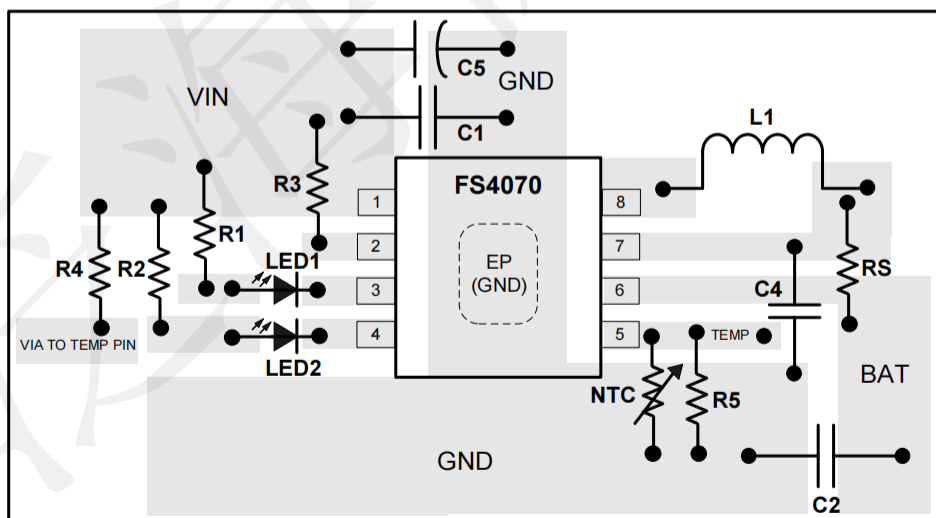

FS4070 Suggested Layout



Typical Application

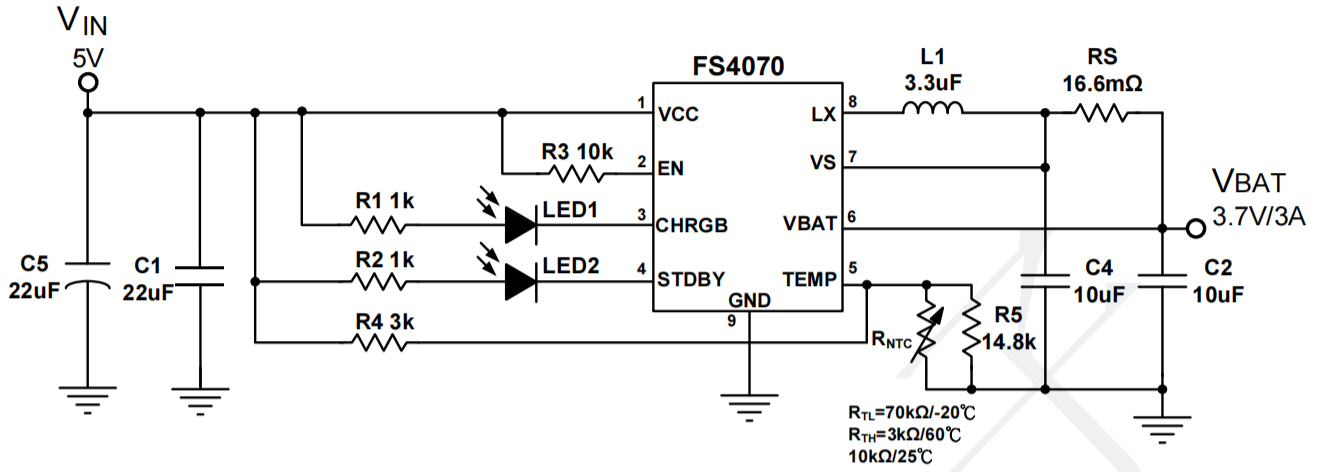

Note:

1. Use ceramic capacitor of X5R or X7R for C1, C2 and C4.
2. Charge Current is recommended for 0.5A to 3.5A.



封装信息

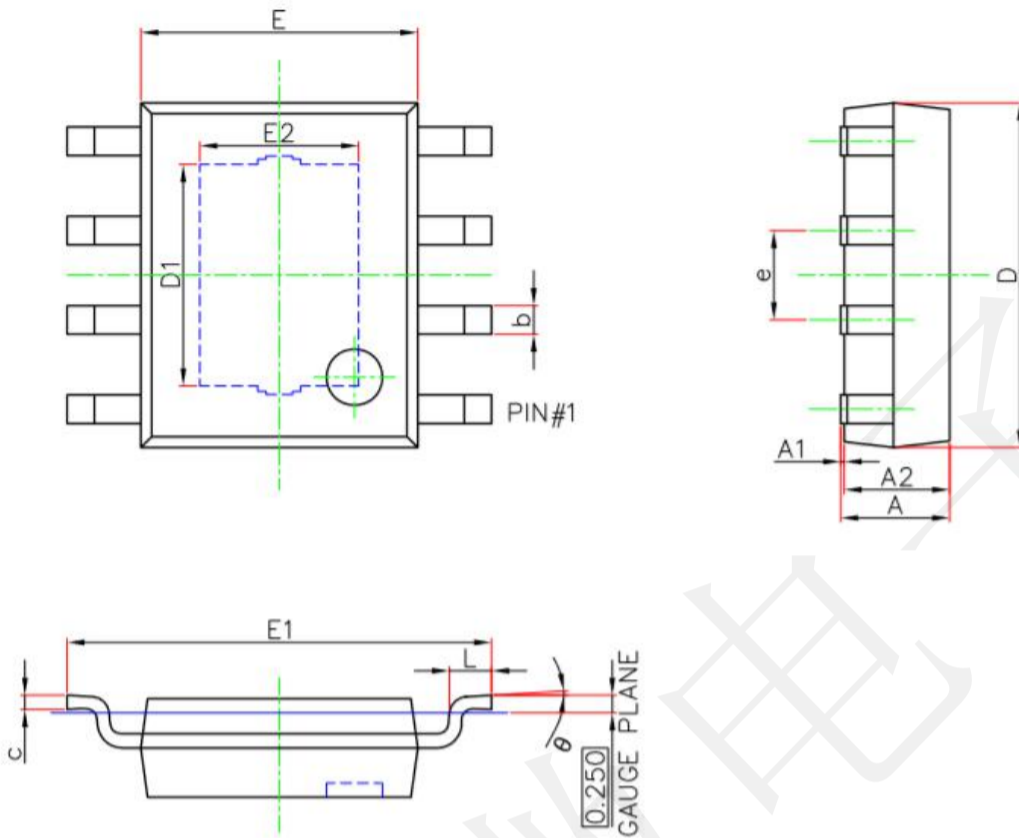

Symbol	Dimensions In Millimeters		Dimensions In Inches	
	Min.	Max.	Min.	Max.
A	1.300	1.700	0.051	0.067
A1	0.000	0.100	0.000	0.004
A2	1.350	1.550	0.053	0.061
b	0.330	0.510	0.013	0.020
c	0.170	0.250	0.007	0.010
D	4.700	5.100	0.185	0.201
D1	3.050	3.250	0.120	0.128
E	3.800	4.000	0.150	0.157
E1	5.800	6.200	0.228	0.244
E2	2.160	2.360	0.085	0.093
e	1.270(BSC)		0.050(BSC)	
L	0.400	1.270	0.016	0.050
theta	0°		8°	